

THIS DRAWING IS UNPUBLISHED. RELEASED FOR PUBLICATION  
 © COPYRIGHT BY TYCO ELECTRONICS CORPORATION. ALL RIGHTS RESERVED.

LOC	DIST	REVISIONS					
FT	64	P	LTR	DESCRIPTION	DATE	DWN	APVD
		AD1		REV PER ECO-06-018765	13APR07	DH	DB

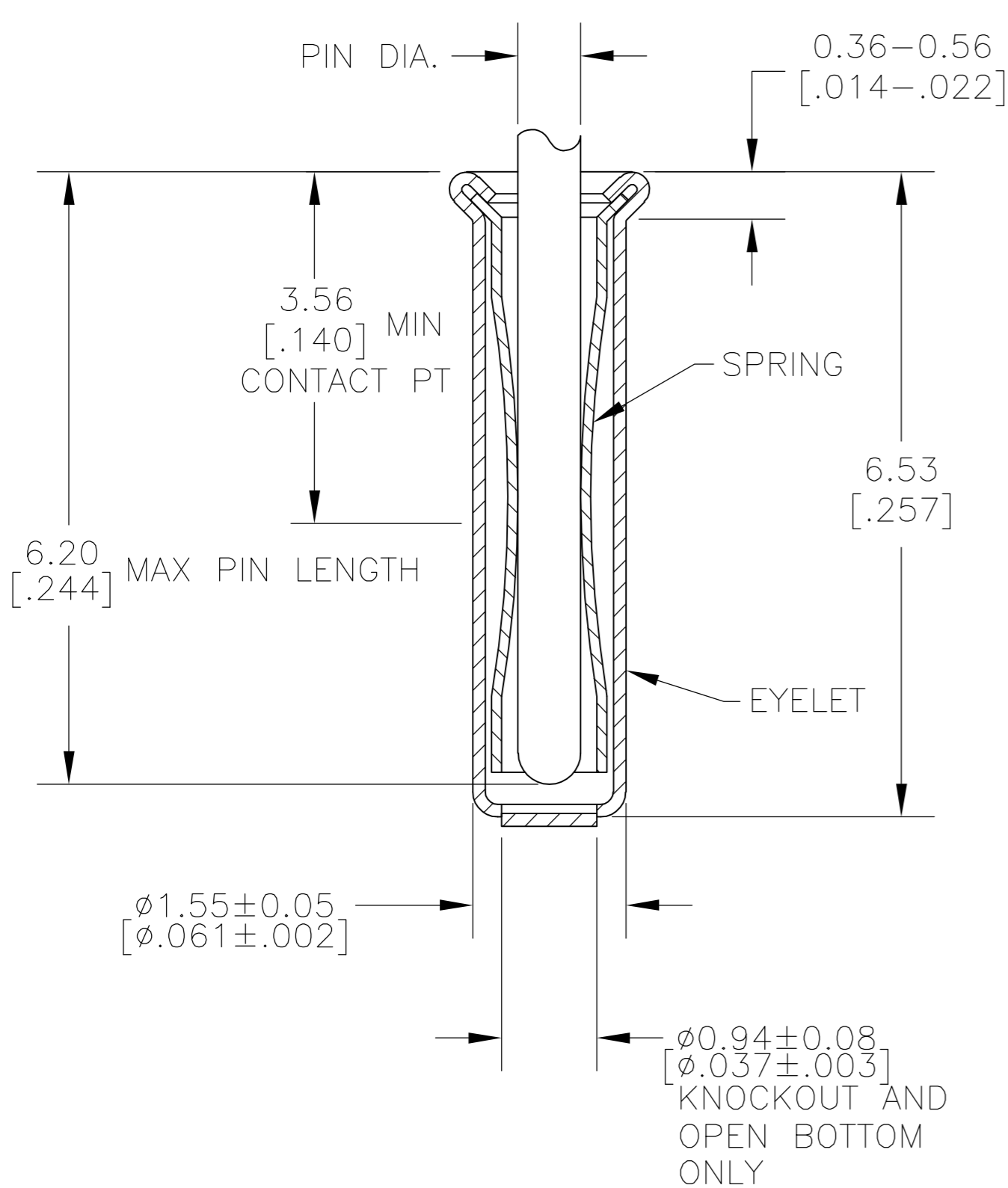
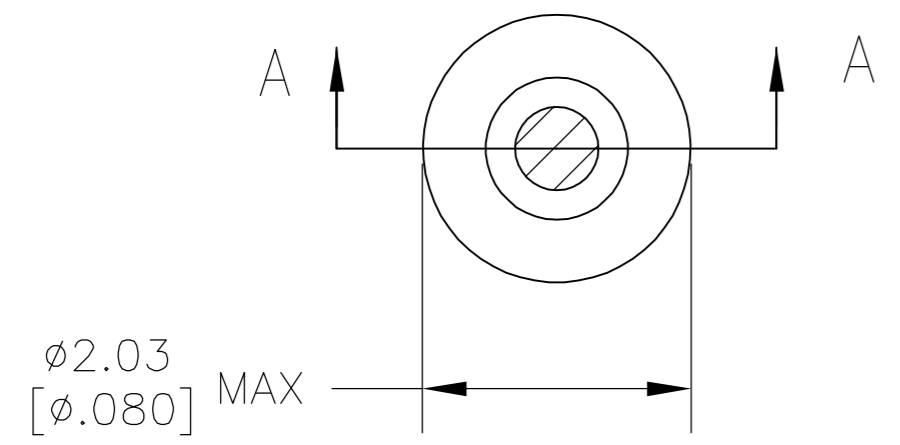

SECTION A-A

- ① TIN PER MIL-T-10727 OR TIN LEAD 0.00254 [.000100] MIN THK.
- ② GOLD PER MIL-G-45204, TYPE II, 0.00076 [.000030] MIN THK OVER NICKEL PER QQ-N-290 0.00028 [.000011] MIN THK ON CONTACT AREA.
- ③ GOLD FLASH PER MIL-G-45204, TYPE II, 0.13 $\mu$ m [.000005] MIN THK. OVER NICKEL PLATE PER QQ-N-290 0.51 $\mu$ m-1.52 $\mu$ m [.000020-.000060] EXT THK.
- ④ TIN PER MIL-T-10727 OR TIN LEAD 0.00381 [.000150] MIN THK.
- 5. RECOMMENDED HOLE SIZE, PLATED OR UNPLATED:  
 MACHINE INSERTION: 1.57  $\begin{matrix} +0.10 \\ -0.08 \end{matrix}$  [.062  $\begin{matrix} +.004 \\ -.003 \end{matrix}$ ]  
 HAND INSERTION: 1.60  $\begin{matrix} +0.10 \\ -0.00 \end{matrix}$  [.063  $\begin{matrix} +.004 \\ -.000 \end{matrix}$ ]
- 6. APPLICATION TOOL PART NUMBER: MACHINE NO. 682127-4  
 INSERTION HEAD NO. 682039-3
- ⑦ TO INSURE PROPER SPRING TENSION DO NOT EXCEED A 0.05 [.002] DIFFERENCE IN PIN DIA WHEN CHANGING TO A SMALLER PIN.
- 8. BOTTOM PLUG KNOCKOUT TOOL PART NUMBER 69729 WITH TIP PART NUMBER 69728-1.
- ⑨ MATERIAL: SPRING: BERYLLIUM COPPER QQ-C-533  
 EYELET: COPPER, QQ-C-576

SUPERSEDED BY 50864-1	CLOSED	0.66-0.84 [.026-.033]	TIN ④	GOLD ②	1-50864-5	
	OBSOLETE				1-50864-3	
	OBSOLETE		OPEN	TIN ①	TIN ①	50864-8
	OBSOLETE		KNOCKOUT			50864-7
			CLOSED			50864-6
	OBSOLETE		OPEN			50864-5
	OBSOLETE		KNOCKOUT	GOLD ③		50864-4
			CLOSED	TIN ①	GOLD ②	50864-3
				TIN ①		50864-1
				GOLD ③		50864
BOTTOM TYPE	RECOMMENDED PIN DIA ⑦	EYELET	SPRING	FINISH	PART NO	

THIS DRAWING IS A CONTROLLED DOCUMENT.		DWN	4-5-91	Tyco Electronics Corporation	
DIMENSIONS: mm [INCHES]		CHK	R.TALLEY	Harrisburg, Pa 17105-3608	
TOLERANCES UNLESS OTHERWISE SPECIFIED:		APVD		NAME	
0 PLC	± -	PRODUCT SPEC		MINIATURE SPRING SOCKET ASSEMBLY	
1 PLC	± -	APPLICATION SPEC		SIZE	CAGE CODE
2 PLC	± -			A2	00779
3 PLC	± 0.20 [.008]			DRAWING NO	RESTRICTED TO
4 PLC	± -			C=50864	-
ANGLES	± -	WEIGHT		SCALE	SHEET
FINISH	-	CUSTOMER DRAWING		20:1	1 OF 1
				REV	AD1